



New Product

IATCO Torque Limiting Clutch Brake



When to Use the Oversize Torque Limiting Clutch Brake

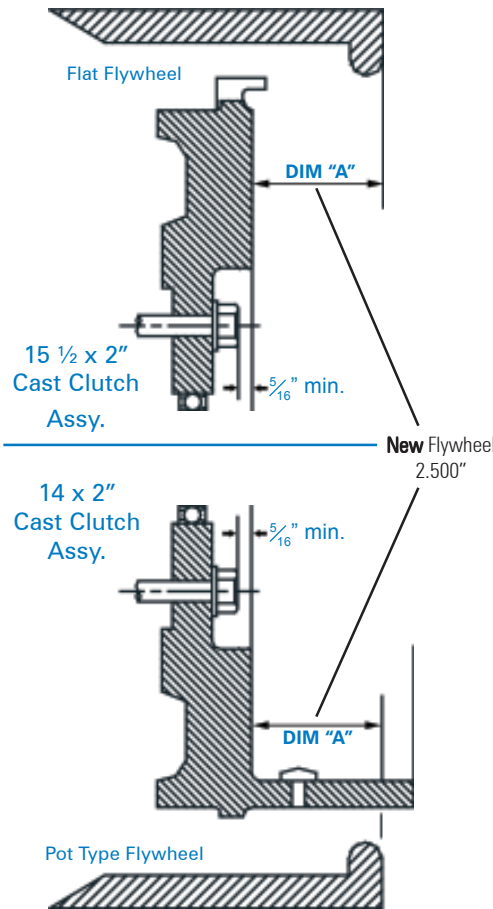

IATCO Torque Limiting Clutch Brake:

Every clutch replacement requires flywheel resurfacing at the time of installation. The use of ceramic friction materials over the past years requires more material be removed in the resurfacing process. This results in the clutch assembly being moved closer to the engine and away from the transmission. Pre-adjustment of the clutch to compensate for a larger "clutch envelope" results in diminished adjustment during the life of the clutch or can even cause malfunction within the clutch assembly.

After installing the resurfaced flywheel, determine dimension "A" as shown in the adjacent drawing. Then select the corresponding torque limiting clutch brake from the table below. Installing a thicker clutch brake will minimize the amount of clutch pre-adjustment and maximize the life of both the clutch and the flywheel.

Torque Limiting Clutch Brakes		
DIM "A"	IATCO Part Number	Description
2.500" - 2.570"	M-1609	1 3/4" Torque Limiting Brake
2.660" - 2.725"	M-1834	1 3/4" Torque Limiting Brake (.500 thick)
2.500" - 2.570"	M-1610	2" Torque Limiting Brake
2.570" - 2.660"	M-1782	2" Torque Limiting Brake (.465" thick)
2.660" - 2.725"	M-1783	2" Torque Limiting Brake (.500" thick)

Available in 3 thicknesses!



1669 Marshall Drive
Des Plaines, Illinois 60018-1840 USA

Telephone: 847-299-1100
Toll-Free: 800-842-1712

Facsimile: 847-299-1205
Toll-Free Fax: 800-942-7660

Website: www.iatcoinc.com
Email: sales@iatcoinc.com

"Best in the Clutch"